

## Technical Data Sheet

### Original Hanau SunCare Magnetic Chokes for UV-Tanning Tubes

#### Ballast 100 LP

**Article No.:** 80006735

**Electrical data:**

Nominal wattage of UV-Tubes:	100 W
Nominal lamp current:	0,98 A
Line voltage:	230 V
Mains frequency:	50 Hz
Electrical contacts for:	L - Lamp
Connection:	Plug in terminals 0,5 - 1,5 mm <sup>2</sup>

**Operating data:**

Temperature rise:	45 K
Intrinsic losses:	16 W (25°C copper temp.)
Max. permissible housing temperature tw:	130 °C
Parallel compensation:	9 µF ±10% 250 V
Weight:	1,3 kg

**Geometric Data:**

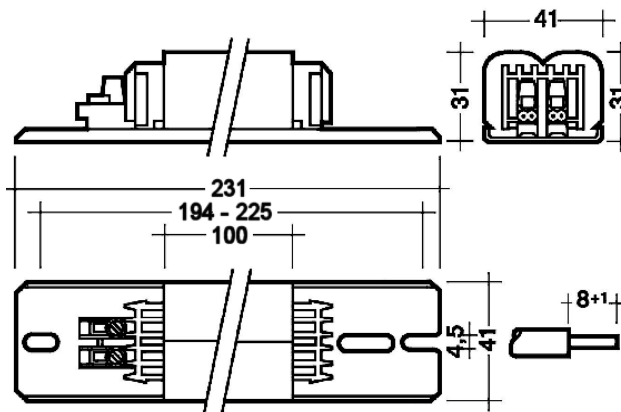

**Approval symbol:**



**Anticipated service life:**

10 years

(for continuous operating with a ballast temperature of 130°C)

The given figures represent typical data based on average values achieved under standardized conditions in the laboratory. For physical/technical reasons operating values are subject to piece to piece variation.

**Heraeus Noblelight GmbH**  
Original Hanau SunCare  
Heraeusstraße 12-14  
D - 63450 Hanau  
Tel.: +49 6181 / 35-5092  
Fax: +49 6181 / 35-5096  
E-Mail: [suncare@heraeus.com](mailto:suncare@heraeus.com)  
[www.original-hanau-suncare.com](http://www.original-hanau-suncare.com)

